

ARCHAEOLOGICAL TEXTILES NEWSLETTER

ATN, 8, 1989

EDITORIAL

Once again the latest issue of the *ATN* reflects the wide range of interests of its readers. We include the first of several notes on the textiles found at the medieval Sudanese site of Kulubnarti by Nettie Adams. These finds are of particular interest to anyone working on Near Eastern textiles and domestic cultures.

There is further information by Avigail Sheffer on the fascinating site of Masada and the production there of textiles. The final report on the textiles from this site is awaited with keen interest.

We are also fortunate in having another note by the eminent Chinese scholar Bao Mingxin on the latest finds in China, notably at the site of Loulan. Bao Mingxin has also expressed appreciation for the number of people who have been in contact with him about Chinese textiles. Such contacts reflect the importance of newsletters such as the *ATN* in keeping people in touch with each other so that they can discuss ideas and problems and exchange information. It is to this end that an informal meeting for discussion will be held in Leiden later in the year for Dutch speaking members of the *ATN* and anyone else who is interested in coming. (It should be noted that the main language of the meeting will be Dutch.) The editors would be interested to hear of any other such meetings and to publish in future issues of the *ATN* any comments or conclusions.

A recent conference in Belgium on the medieval textiles from the Maas-Rhine region was also covered by various members of the *ATN* who seem to have enjoyed themselves tremendously - both with respect to the lectures and the social contacts!

In this issue of the *ATN* we have included the specific bibliographies of two scholars interested in very different areas of work, namely the Chinese historian Bao Mingxin and the Danish archaeologist Elisabeth Munksgaard. If anyone has ideas about other personal bibliographies, could they please write to the editors. Also included in the main bibliography are a number of more general works. Again the editors would appreciate it if subscribers would either send copies of new articles or the titles of recently published works to the *ATN*. The bibliography is one of the main elements of the *Newsletter* but the editors need help in compiling it. Don't be modest!

A number of subscribers have also expressed an interest in including New World textiles in the *ATN*. The idea about notes etc. has been discussed by the editorial board but we feel that if we did so the *Newsletter* would become too diverse. We would however be very interested in hearing from anyone who wished to set up a sister newsletter to the *ATN* which covered this area. Needless to say we are still interested in hearing about textiles from the Old World are to be found in the Americas.

SUBSCRIPTIONS ARE DUE AGAIN! We are glad to announce that we have been able to keep the price of the *ATN* at Fl 15 (or pounds sterling equivalent) for yet another year!

Subscriptions should be sent to G. M. Vogelsang-Eastwood at the address given in the colophon.

Could subscribers please pay in either Dutch guilders or pounds sterling. It costs us the equivalent of \$3 to cash a \$4 cheque.

Colophon

The Archaeological Textiles Newsletter
Published in Leiden The Netherlands
ISSN 0169-7331

EDITORIAL BOARD L Bender Jørgensen
G M Vogelsang-Eastwood P Walton and
J P Wild

PUBLICATION DATES Twice-yearly May and
November

DEADLINES FOR CONTRIBUTIONS April 1st and
October 1st for the May and November issues
respectively

CONTACT ADDRESS G M Vogelsang-Eastwood
Van Swietenstraat 45 NL-2334 EA Leiden The
Netherlands

SUBSCRIPTION CHARGES Dfl 15 00 (or the
equivalent in pounds sterling) per annum
(two issues)

Subscription payments can be sent to G M
Vogelsang-Eastwood at the above address (in
the form of bank cheques or postal orders)
or money may be transferred to the following
Dutch Giro Account G M Vogelsang-
Eastwood 2567328 again using the contact
address given above

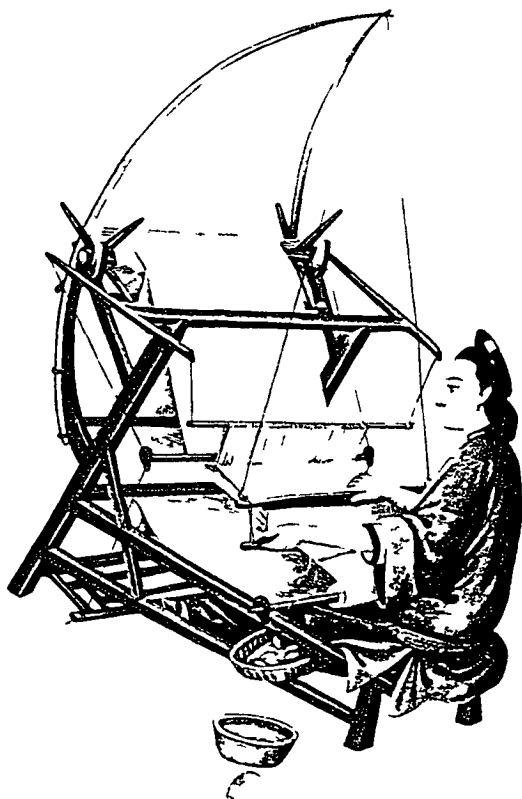

NOTES TO CONTRIBUTORS

The *Archaeological Textiles Newsletter* aims to provide a source of information for those who are studying textiles primarily as archaeological objects. Contributions to the *Newsletter* are welcome and should be in accordance with this concept

1 Contributions can be in English German or French. If necessary items in Russian will be accepted but these will be translated into English

2 Contributions may include short (') references to recently published books journals articles and to forthcoming exhibitions seminars conferences special courses lectures etc information concerning work in progress (see note 3) and any queries concerning the study of archaeological textiles

3 Work in Progress this is a general category which includes for example work on archaeological textiles from recent excavations or in museums. Items in this section should contain information (if available) about the following: where the textiles were found, the relevant dates, who excavated the site and when, the range of textiles found, who is responsible for the cataloguing of the textiles and where they are to be published. These notes should not exceed a maximum of five hundred words per item. Maps showing the position of the relevant sites would be greatly appreciated

4 Line drawings will be considered but photographs cannot be accepted at present

5 The editors reserve the right to suggest alterations in the wording of items sent for publication

6 The deadline for contributions is the 1st April and the 1st October for the May and November editions respectively

The views expressed by the various authors are not necessarily those held by the editors

LOGO

The logo is taken from the famous depiction on a Hallstatt urn found at Odenburg/Soporn Hungary. The original illustration shows three women who are spinning and weaving

LATE MEDIEVAL TEXTILES FROM KULUBNARTI (part 1)

The Museum of Anthropology at the University of Kentucky is in the process of accessioning a textile collection from the archaeological site of Kulubnarti. Located in the Sudan at the upper end of Lake Nubia, this medieval town site was occupied between A D 1200 and 1400.

The collection of 118 specimens was recovered from the domestic refuse of the houses and streets of the town. This origin is reflected by the fragmentary nature of the remains. Only one specimen is complete, a small bag. The rest are parts of garments, pieces of woollen mantles and head veils, and portions of animal girths, rugs, and heavy bags.

The characteristics of the collection are familiar from other sites of the same period. Wool, cotton, flax, goat hair, and camel wool are present. Woollen fragments are the most numerous, comprising 54.4% of the total. Cotton is next in frequency with 34.4%. Goat hair pieces amount to 4.4% and flax accounts for only 1.5% of the total. The remaining 5% includes camel, unidentified, and fabrics made of two fibers.

Among the woollen fabrics, a dark brown s-spun plain weave type is the most numerous. Thread counts range from 5 wp/6 wf in a coarse yarn which makes a heavy blanket-like cloth to 10 wp/14 wf in a much finer yarn with a more open weave. Exactly half of the fragments of this type have thread counts between these two extremes, forming a medium category. Fragments with decorative bands embroidered in blue, green, red, orange, and natural yarns amount to 12.5% of this type.

Other fabric types among the wools include 3 blue and 2 red fragments of head veils (s-spun fine yarn open weave) and 9 fragments of s-spun weft-faced cloth having bands of alternating colors. These include pale blue, dark blue, natural red, and brown. Two specimens of 2/2 twill occur. One in medium blue is s-spun, the other specimen in dark blue has one system z-spun while the second system is s-spun.

Turning to the cotton fabrics, all of them are plain weave and 75% are z-spun. These are the same z-spun types so numerous at Qasr Ibrim. Of these, 10% are piece-dyed blue, the remaining 90% are undyed. A type of undyed cotton with s-spun yarns is present here also, accounting for almost 20% of the cotton fragments. This type has fine irregularly spun yarn and appears to be poorly beaten up. It seems much less standardized than the z-spun cotton cloth or the s-spun cottons of the Meroitic and X-Group periods, almost a millennium earlier.

Other cotton fabrics include one warp-faced z-spun blue specimen of a type common at Quseir al-Qadim and Qasr Ibrim, two examples of s-spun weft-face undyed cloth with paired brown wool wefts occurring at widely spaced intervals, blue and white windowpane check with z-spun yarns, and a blue piece with s-spun yarns in one system and z-spun in the other.

Flax fabrics are all plain weave. Three fragments are s-spun and undyed, one is a blue and white windowpane check with yarns spun in both directions in each system. Two fragments of fustian complete the list of flax.

In terms of weaves, the goat hair and camel wool specimens are by far the most interesting. In order to do justice to this material, their descriptions will be dealt with in a later contribution.

N K Adams
Associate Curator
Museum of Anthropology
University of Kentucky,
Lexington, USA
Ky 40506-0024

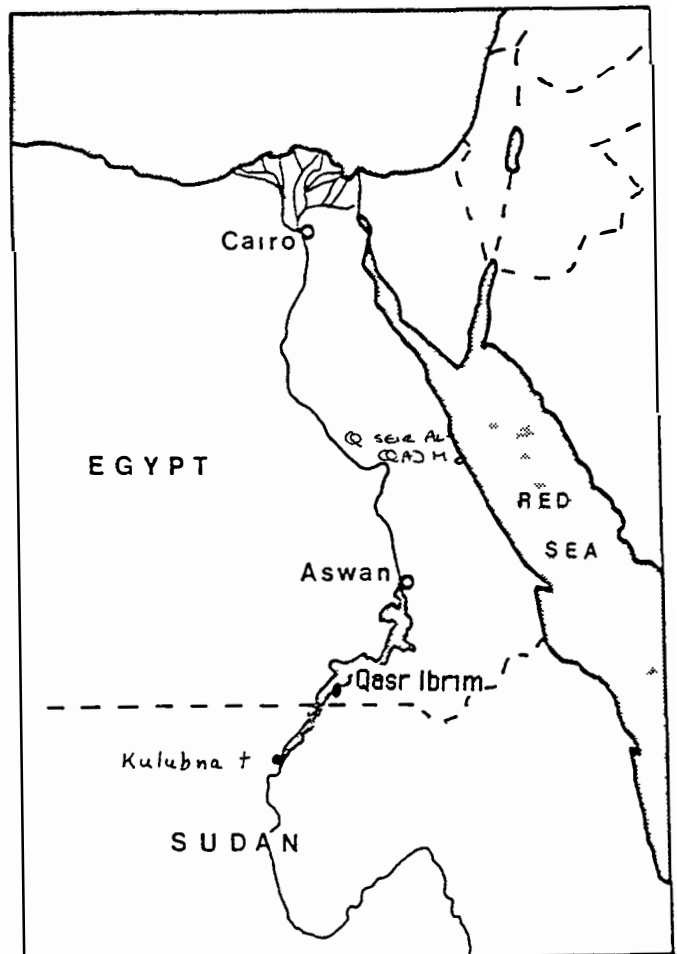

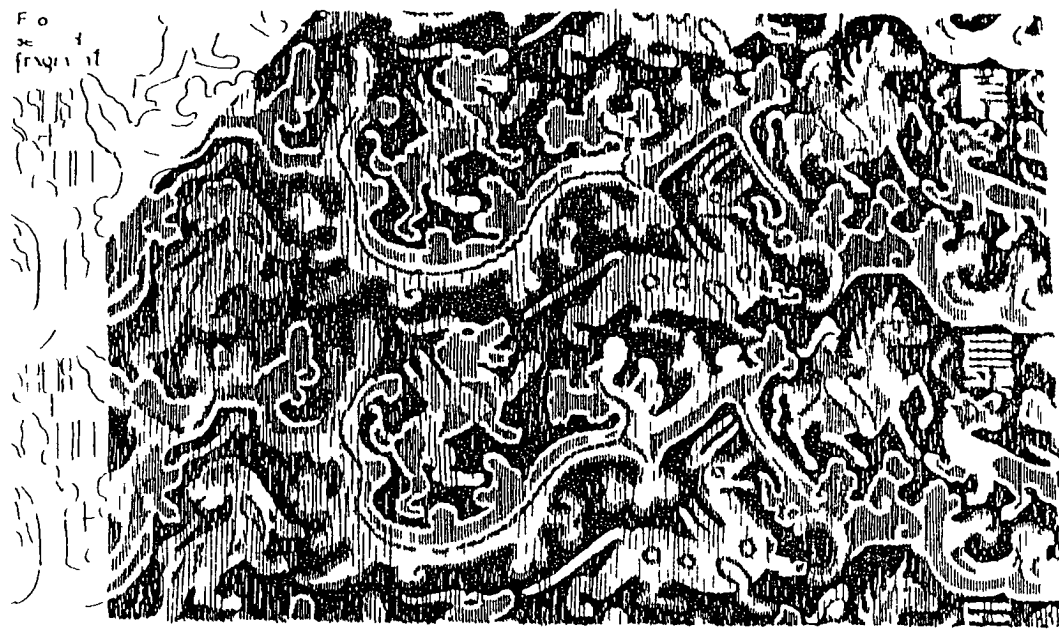
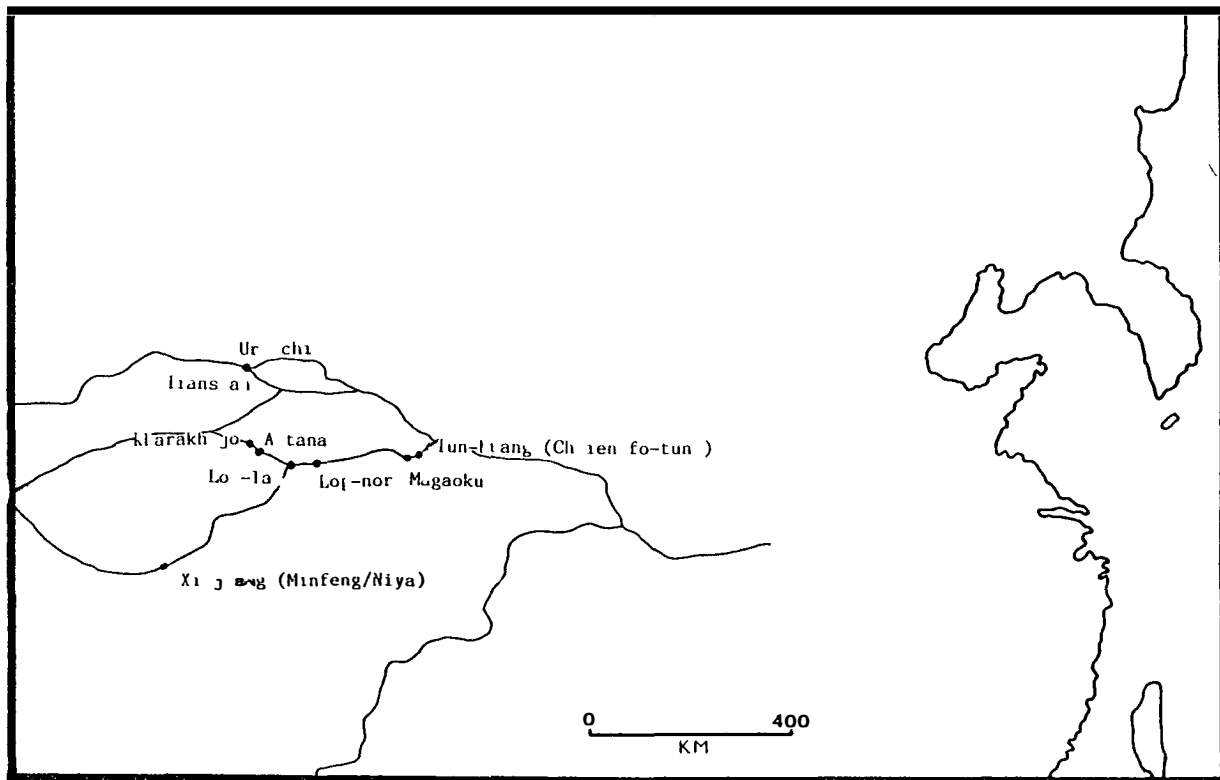

In tes

	Dk l G Dk l f L b f C m b D l f b l f f H b Sl l G (p 2)	
--	--	--

DRAWING SHOWING PATTERN OF FIGURED SILK ABRIC LC OII
FROM GRAVE PIT OF LOU LAN CEMETERY LC

CEMETERIES ON THE OUTSKIRTS OF LOULAN CHINA

In March and April 1980 an archaeological team from Loulan Xinjiang conducted an investigation and trial excavations at the site of the ancient city of Loulan. The surveys took place at almost the same place where Sir Aurel Stein excavated 66 years ago. The investigated cemeteries are alleged to be Late Western Han Dynasty to early Eastern Han in date i e 206 B C - A D 220 [1]. Many items of costume and textiles were unearthed from the two cemeteries catalogued as MA and MB. Seven tombs in MA and two in MB were excavated.

There are 75 pieces of silk among the finds including *Jing* (brocade) *Qi* (plain-weave damask) *Juan* (plain silk) and embroidery all from tomb MB2 except one piece of yellow *Juan*.

There are 53 pieces of warp-pattern brocade using two or three different colours of warp threads in each piece. Their weaves are similar to those found in former excavations. Some pieces are exactly the same as LC 111 011 unearthed by Sir Aurel Stein (fig 1) [2]. Many of these brocades use Chinese characters as part of their patterns which have never been found before. There are 5 pieces of damasks woven by a method of weave known as Han-weave (or *armure Han*). The only piece of embroidery has a yellow floral pattern worked in chain stitch on a blue *Juan* ground. It was attached to a white cotton cloth.

There were 22 items of woollen fabric including tapestry rug felt and coloured checks. One of the tapestries has a pomegranate pattern. Another fragment has a colour-striped border which was made with a special raising finish which has given it a slightly napped surface.

There are also 5 items of cotton cloth which are all undyed made by plain weave.

Almost all of the clothing worn by the corpses has rotted except one leather boot with felt lining. But there is one piece of a very small-sized silk robe (fig 2) which was supposed to be worn by the spirit of the dead instead of having any practical use. The robe is 15 cm from the collar to hemline, 17 cm at the waistline and has a sleeve length of 65 cm.

Bao Mingxin
China Textile University
1882 West Yan-an Road,
Shanghai
People's Republic of China

[1] *Wenwu* (July 1988) 1-39

[2] Sir Aurel Stein *Innermost Asia* (1928)
253 pls XXXIV XXXVIII

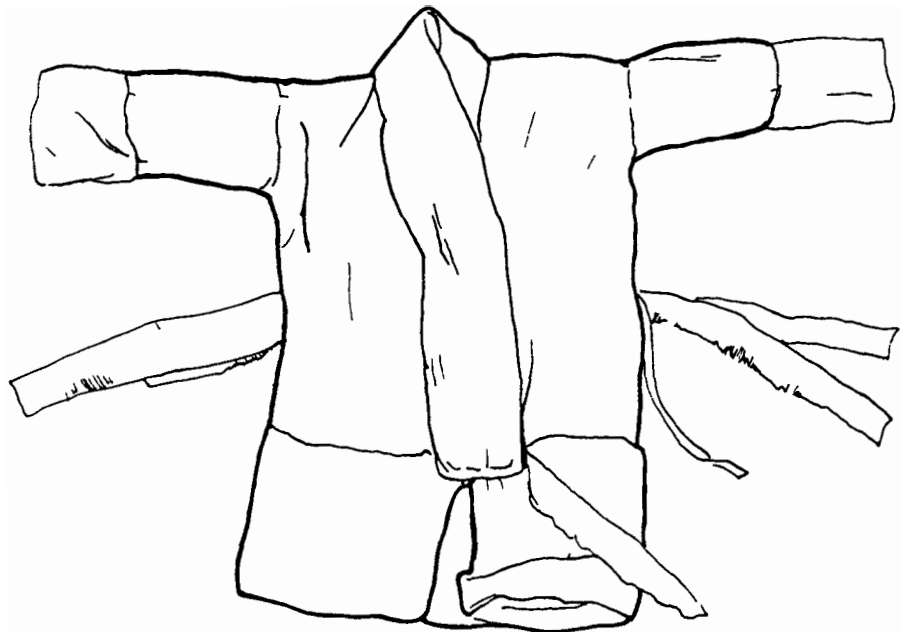

MASADA - LOOMWEIGHTS

Loomweights have been found in Building XIII and in 8 of the casemate wall rooms at Masada

From four of the rooms only one or two loomweights were brought to Jerusalem. This does not mean that there were not many more. All the loomweights were unbaked and sun dried. They were therefore very fragile.

A comparison between the written daily report of the excavator and the number of loomweights brought to Jerusalem is amazing. According to the daily report 45 loomweights were found in L 1108 but only 24 were brought to Jerusalem. In L 1242 again according to the daily report 30 loomweights were found but only 4 were brought to Jerusalem.

Remnants of pieces of burnt wood were found in three of the casemate wall rooms. The excavator wrote that in L 1103 there were remains of a loom which had either fallen from the second floor or was in the basement. In locus 1269 in the northern

eastern corner remains of wood belonging to a loom could be seen. In L 1108 near the snake gate the excavator not only found the remains of burnt wood but a cord was still extant in the loomweights inside the middle hole and on the plastered wall signs of burnt cords could also be observed. Loomweights were also found in these three loci.

It is probable that weaving was practised by the families living at Masada during the seven years of occupation. Nevertheless the questions as to what sort of weaving was carried out and what range of material was used for the weaving will only be resolved when all the material has been cleaned, sorted, studied and published.

A Sheffer
 Institute of Archaeology
 Tel Aviv University
 Ramat Aviv 69 978
 Tel Aviv
 P O B 39040
 Israel

LOOMWEIGHTS FROM MASADA

locus no	no of weights brought to Jerusalem	size and form	excavator's remarks
816 (building 13)	4	different sizes	-
1103 near the snake gate	16	different sizes 140-120 grams	20 loomweights pieces of wood and iron. The loom probably fell with the collapsed second floor.
1103	2	doughnut 230 grams	-
1108 near the snake gate	24	conical 200-270 grams	45 loomweights remains wood a cord is still in some of the loomweight holes. Signs of burnt strings remain on the plastered wall.
1143	2	440 grams	-
1202	1	280 grams	-
1241	4	conical	30 loomweights
1244	2	180 grams	-
1261	16	conical elongated 95-270 grams	Remains of a loom, wood and loom-weights were found in the north-eastern corner.

MEETINGS AND SYMPOSIA

The 7th annual Conference on Textiles University of Maryland College Park will be held from June 23rd-26th 1989. The topics to be covered at the meeting will relate to the history theory practice and development of textile knowledge. For further information about this conference please contact Dr C Anderson or Dr B Pourdeyhimi University of Maryland 2100 Marie Mount Hall College Park MD 20742 USA

MEDIEVAL TEXTILES IN THE MAAS-RHINE AREA

When the Provinciaal Museum voor Religieuze Kunst at Sint Truiden in the Belgian province of Limburg announced a four-day congress on medieval textiles from the Maas-Rhine Euregion the response was immediate and overwhelming. The fortunate 60 who attended the gathering held in the restored medieval castle of Alden Biesen from 13-16th February 1989 enjoyed a programme of lectures and visits that revealed the unsurpassed richness of the region's textile collections.

Byzantine silks were the principal object of attention. Liège Tongeren Maastricht and Aachen displayed to us their ecclesiastical textile treasures and those in charge of them reviewed their importance in a series of comprehensive papers. On other outings participants were able to see the conservation and research facilities in the Koninklijk Instituut voor het Kunstpatrimonium in Brussels and the Deutsches Textilmuseum, Krefeld. Technical papers delivered at Alden Biesen were devoted *inter alia* to current research on dye analysis on the manufacture of metal thread and on the weaving technology of late antiquity.

As always it was the opportunity to question discuss and argue that was one of the most valuable features of the congress but a concert of early music and a banquet of Limburg (nouvelle) cuisine given by the Province of Limburg were memorable distractions. The organisers - Leon Smets Suzy Bangels Betty Simon and Oscar Lauwens - left nothing to chance in a superb example of sound conference management. The congress papers will be published in the near future and a second congress is promised for two years hence.

J P Wild

INFORMAL MEETING FOR DUTCH SPEAKING MEMBERS OF THE ATN

We hope to hold an informal meeting for Dutch speaking members of the ATN and anyone else who may be interested on the 3rd November 1989. This one-day event will take place at the Rijksmuseum voor Oudheden Leiden. It is proposed that there will be six or seven speakers giving talks about various aspects of current research for example textiles from wet and dry sites museums and archaeological textiles the conservation of archaeological textiles. One of the most important aspects however will be the opportunity for us to meet each other in an informal atmosphere.

If anyone is interested in participating could they please get in contact with G M Vogelsang-Eastwood at the address given below.

Please note that most of the meeting will be in Dutch!

G M. Vogelsang-Eastwood
Van Swietenstraat 45
2334 EA Leiden
The Netherlands

Der Schneider.



Ich bin ein Schneider/mach ins Feld/
Den Kriegesfürsten ire Zelt/
Mach Reißdeck zu Stechn vnd Thurnier/
Auff Welsch vnd Fransösisch Manier/
Kleid ich sie ganz höfflicher art/
Ire Hofgsind vnd die Frauen zart/
Kleid ich in Sammet Seiden rein/
Vnd in wollen Thuch die Gemein.

DEIR ALLA EXHIBITION

On August 25th an exhibition will be opened at the Rijksmuseum van Oudheden in Leiden The Netherlands about the excavations at Deir Alla Jordan The theme of the exhibition will be Deir Alla in the 9-8th centuries B C Included amongst the exhibits will be a stand about the textiles and objects relating to the production of textiles spindles and whorls loomweights pin beaters etc which were found at the site

A catalogue of the exhibition will be available in either Dutch or English

The exhibition will run until Christmas

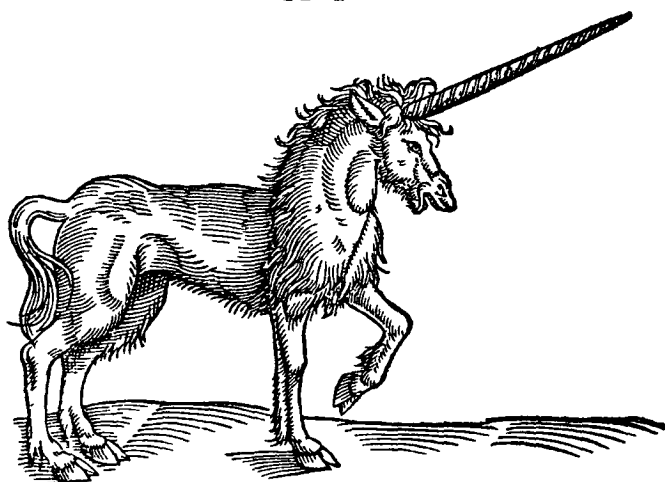

MISCELLANEOUS

Anne Morrell is collecting material for a practical guide to the identification of seams hems openings darts pleats repairs etc to be used by those concerned with archaeological textiles She would appreciate it if anyone with relevant information based on archaeological and historical textiles from the Old World would get in contact with her at the address given below

Line drawings a brief description (about 30-50 words) name of feature(s) (plus any synonyms) and bibliographical references would also be appreciated

It is hoped that this work will appear in the near future as an ATN occasional paper in conjunction with Manchester Polytechnic

A Morrell
Manchester Polytechnic
Dept of Textiles/Fashion
Cavendish Building
Cavendish Street
Manchester M15 6BG
England

RUE'

Does anyone have any information about a plant called RUE or RUI grown in Hadramaut which was used for dyeing? It is mentioned in a Portuguese Asian text from the 17th century A D as a dye source but in the only reference so far found in a Portuguese dictionary it is described as *Calatropis gigantea* Br a medicinal plant Duarte Barbosa *Livro do Oriente* 1516 mentions a dye plant RUUIA from the Yemen What are the (South) Arabian dye plants and could RUE and RUUIA (or RUIVA) be the same?

If anyone can help on this point could they please get in contact with B N Teensma at the address given below

B N Teensma
St Jacobsgracht 2A
2311 PW Leiden
The Netherlands

COPTIC AND PHARAONIC TEXTILES A CO-PRODUCTION

An old idea has been revived' The publication of a catalogue of the Coptic textiles in the Rijksmuseum van Oudheden in Leiden The Netherlands is going ahead (ATN 1 11 2 8-9) The original plan has been extended into a joint publication of both the Coptic and Pharaonic textiles The museum possesses about 250 pieces of the latter

The co-authors are Gillian Vogelsang-Eastwood and Ingrid Blom for the Pharaonic textiles and Philomeen van t Hooft for the Coptic textiles Work on this joint catalogue has only recently started and the date of publication is closely connected with the conservation of some of the Pharaonic pieces Since the first announcement of the forthcoming publication conservation on the Coptic textiles has proceeded slowly but it has now almost been completed

P van t Hooft
Reek 13
2121 GT Bennenbroek
The Netherlands

A Kruse B Bøggild Johannsen C Paludan
 L Warburg and E Østergaard *Fru Kirstens
 Børn To Kongebørns Begravelser i Roskilde
 Domkirke* (Lady Kirsten's Children Two
 Royal Children's Burials in the Roskilde
 Cathedral) Poul Kristensens Forlag National
 Museum Copenhagen (in Danish but with a
 long English summary The captions to the
 illustrations are all in Danish and
 English)
 296 pages numerous colour and black and
 white photographs
 ISBN 87-7468-247-4
 Price Danish Kr 288

A detailed account of the clothing found
 in the coffins of a son and daughter of Lady
 Kirsten Munk and Christian IV of Denmark.
 The children died in the late 1620s but
 the actual burials date to the 1650s.
 During the conservation of the royal burials
 in the early 1980s a large quantity of
 cloth was found. The textiles came from
 various countries including Denmark, The
 Netherlands, France, Spain, Italy and the
 Orient. Included among the finds are caps,
 quilts, embroidered pillows, lace, sashes,
 night-jackets, silk, damasks, gold
 embroidery, a knitted jacket and stockings.
 All of the items have been recorded in
 detail and illustrated in colour. A
 catalogue of the finds has been given in
 Danish and English.

After careful examination and
 photographing the children and their burial
 clothes were once more laid to rest in their
 coffins and placed in the crypt of Roskilde
 Cathedral.

*Nederste ærmebort
 Slids med tre masker på hver
 side. Derover begynder den lod-
 rette ærmebort med udtagninger
 jævnt fordelt til ærmets bre-
 dste mål er næt.*

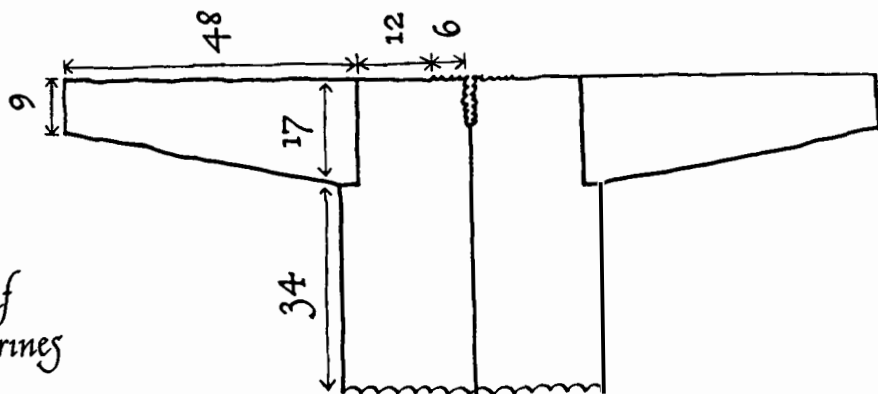
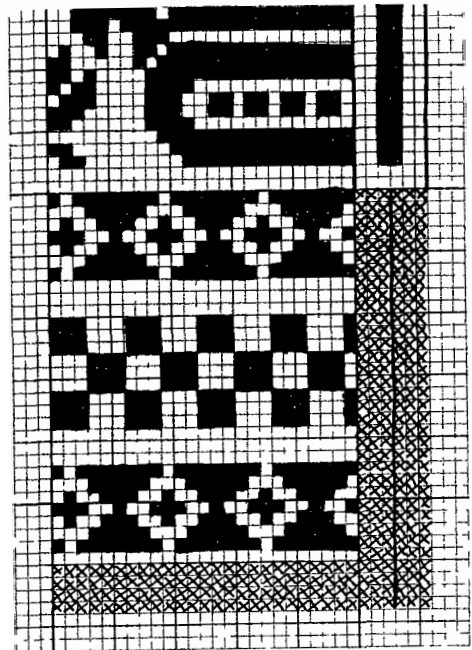

*Opmåling af
 Maria Cathrines
 trøje*

Terminologie und Typologie Mittelalterlicher Sachgüter Das Beispiel der Kleidung Internationales Round-Table-Gespräch Krems an der Donau 6 Okt 86 Veröffentlichungen des Institutes für mittelalterliche Realienkunde Nr4 10 Verlag der Öster Akademie der Wissenschaften Wien (1988) ISBN 3 7001 1461 3

Dieses Buch is aus einem internationalen Round-Table-Gespräch über die wissenschaftliche Behandlung von mittelalterlichen Sachgütern entstanden als Beispiel diente dazu die Kleidung Es ist bekannt dass die Bezeichnung von historischen aber auch heutigen Kleidungsstücken in allen Sprachen durch den Wechsel der Mode aber auch Beibehaltung alter Namen bei der Tracht in einzelnen Gebieten variiert

Von den verschiedenen Autoren ist versucht worden schriftliche und bildliche Überlieferungen aus der Zeit des Mittelalters zu finden die für ein bestimmtes Kleidungsstück eine allgemeine Bezeichnung ergeben Dies ist nicht nur im Bereich der deutschen Sprache geschehen Man hat auch versucht in der französischen in der niederländischen und der englischen Sprache dazu Beziehungspunkte zu finden die eine Lösung des Problems möglich machen Im wesentlichen wurden von allen acht Autoren als Quellen die Minnedichtung Kleiderordnungen Nachlassinventare und Dokumente aller Art herangezogen Das Problem Bezeichnung und bildliche Wiedergabe von historischen Kleidungsstücken in einem begrenzten Gebiet zu einem eindeutigen Terminus zu führen hat Ruth Schmidt-Wiegand in ihrem Aufsatz Kleidung Tracht und Ornat nach den bilderhandschriften des Sachsen spiegels zu lösen versucht Der Sachsen spiegel ist zwischen 1225 und 1235 geschrieben worden und mit Zeichnungen versehen

Mit Problemen aus dem allgemeinen Gebiet der Kleidung haben sich Gerhard Jaritz Mittelalterliche Realienkunde und Fragen von Terminologie und Typologie Probleme Bemerkungen und Vorschläge am Beispiel der Kleidung Elisabeth Vavra Bemerkungen zur Kostümliteratur und Leonie von Wilckens Terminologie und Typologie spätmittelalterlicher Kleidung Hinweise und Erläuterungen auseinandergesetzt was schon

in dem Titel um Ausdruck kommt

Jutta Zander-Seidel hat die Standische Kleidung in der mittelalterlichen und frühneuzeitlichen Staat behandelt und dabei die gut dokumentierten Verhältnisse in Nürnberg herangezogen

Das mittelalterliche Kostüm in den Niederlanden ist von Mireille Madou untersucht worden wobei die Verwandtschaft mit der deutschen und französischen Sprache zu Erklärungen der Kleidungsbezeichnungen führen kann Damit wird auf den internationalen Zusammenhang hingewiesen den man für die Bezeichnung einzelner Kleidungsstypen erreichen will

Helga Schüppert versucht unter dem Titel Bezeichnung Bild und Sache Überlegungen zur Kleidungsterminologie um 1500 Klassifizierungskategorien Modekritiken Nachlassinventare usw zu den schon genannten Auseinandersetzungen in der Literatur wie zu den bildlichen Wiedergaben zu bringen Sie will damit aufzeigen wie man systematisch an die Probleme herangehen muß um sie zu lösen in dem man Fragen stellt wie zum Beispiel nach dem Material nach der Herstellung nach der Form, nach prominenten Trägern usw Damit kommt man den praktischen Fragen nach der Herstellungsweise Schnitt Material usw am nächsten die in den anderen Arbeiten weniger berücksichtigt worden sind Denn Schnittbücher oder handwerkliche Schneiderordnungen geben ebenfalls Auskunft und können die Terminologie klären helfen

Der letzte Beitrag von Robert Jütte Windfand und Wetterhahn die Kleidung der Bettler und Vagabunden zeigt die Schichten die an der Grenze der mittelalterlichen Kultur leben Er greift darin auf Robin Hood zurück und bringt damit eine gewisse englische Terminologie in diesen Themenkreis herein

Eine Festlegung von Bezeichnungen bestimmter Typen mittelalterlicher Kleidungsstücke die aber mehrfach herangezogen wurden ist in diesem Zusammenhang noch nicht durchgeführt worden Es werden die Probleme auf dem sprachlichen Sektor angeschnitten und auf Lösungsmöglichkeiten hingewiesen die Forschung hat die eignen Sprachgrenzen zu überschreiten um zu einer richtigen Interpretation der mittelalterlichen Kostüminterminologie zu kommen

I Petrascheck-Heim
A-1190 Wien
Dionysius-Andrassy-Strasse 16
Austria

P Walton *Textiles Cordage and Raw Fibre from 16-22 Coppergate The Archaeology of York 17/5* (1989)

Published by the Council for British Archaeology for the York Archaeological Trust

172pp 53 line illustrations 20 plates catalogue

£18 00/\$32 50

March 1989

This report describes over 200 wool silk and linen textiles including patterned linens imported silks and a sock in *nålebinding* technique. The finds have been analysed to provide evidence for methods of fibre preparation weaving dyeing and needlework and the general evolution of the textile industry in the 9th-14th centuries.

A D Chapter headings include Comparative Material Fibres (their preservation and identification) The Textiles in Context (an attempt to place them against their historical background) Dyes Detection and Identification and Conservation of the Finds

For further information write to York Archaeological Trust 1 Pavement York YO1 2NA England



BIBLIOGRAPHY

- Autour du fil* L Encyclopédie des arts textiles 16 volumes (vol 1-4 issued) 1988- Edited by Fait Main the Bonniers group ISBN 2-907569-00-7
- A Bartel & W Lampe Ein Griffzungenschwert mit Gewebe- und Fellresten aus Puddemin Kr Rügen *Ausgrabungen und Funde* 33 (1988) 120-126
- J Besancenot *The Traditional Costumes of Morocco*, Kegan Paul London (1989) £50
- L Bender Jørgensen Textile remains from Diverhøj *Journal of Danish Archaeology* 6 (1987) 152
- L Bender Jørgensen Searching for new knowledge about early textile handicrafts *Danish Handicraft Guild* 5 1988 14-19
- L Bender Jørgensen På jagt efter ny viden om oldtidens tekstilhåndværk *Haandarbejdets Fremme* nr 5 1988 14-19
- L Bender Jørgensen Auf der Jagd nach neuen Wissen über das Textilhandwerk der Vorzeit *Die dänische Handarbeitgilde* 5 1988 14-19
- L Bender Jørgensen Textilfunde aus dem Mittelelbe-Saale-Gebiet (Eisenzeit bis frühes Mittelalter) *Jahresschrift für mitteldeutsche Vorgeschichte* 71 (1988) 91-123
- G Bhadra The role of Pykars in the silk industry of Bengal (c 1765-1830) pt 1 *Studies in History* (New Delhi) 3 no 2 (1987)
- G Bhadra The role of Pykars in the silk industry of Bengal (c 1765-1830) pt 1 *Studies in History* (New Delhi) 4 no 1 and 2 (1988) 1-36
- E Crowfoot Textiles from Ardale Anglo-Saxon cemetery in T J Wilkinson *Archaeology and Environment in South Essex Rescue Archaeology along the Grays By-pass 1979/80* (1988) 54
- M Fentz Af skjortens saga *Skalk* (1 1989) 7-11
- M Flury-Lemberg Ein spätantikes Seidengewebe mit Nilszene *Zeitschrift für Schweizerische Archäologie und Kunstgeschichte* 44 (1987) 9-15
- M Flury-Lemberg *Textil-konservierung im Dienste der Forschung Ein Dokumentarbericht der Textilabteilung zum zwanzigjährigen Bestehen der Abegg-Stiftung* Bern (1988 ISBN 3-905014-01-7 English version also available Price about £100)
- H Fujii Roman textiles from At-tar Caves in Mesopotamia *Mesopotamia* XXII (1987) 215-232
- B Hougen *Osebergfunnets Billedvev* (n d recent booklet on Viking period embroideries based on an article which appeared in *Viking* IV 1940 85-124)
- H -J Hundt Textilreste aus awarischen Gräbern von Leobersdorf und ein Excurs über gegoßene Textilstrukturen an der Rückseite bronzener Riemenzungen in F Daim. *Das awarische Gräberfeld von Leobersdorf NÖ* (Studien zur Archäologie der Awaren 3) Vienna (1987) 9-17
- H -J Hundt Ein Textilrest aus dem urnenfelderzeitlichen Depotfund von Sublaines *Archäologisches Korrespondenzblatt* 18 (1988) 261-262
- U Körber-Grohne Microscopic methods for identification of plant fibres and animal hairs from the prince's tomb of Hochdorf Southwest Germany" *Journal of Archaeological Science*, 15 (1988) 73-82
- W Kubiak and G T Scanlon, *Fustat-C Fustat Expedition Final Report*, New York (1989) An introduction to the medieval site of Fustat Egypt it includes sections on textiles (by L Mackie) basketry and leather ISBN 0-036770-21-X \$32 50 (ARCE Reports no 11)
- J Jackman (ed) *The Fibre Structure on Leather* Leather Conservation Centre London (1985 £5 00)
- S Landi *The Textile Conservator's Manual* Butterworths London (1985 £54 50)
- J Maik *Wyroby włókiennicze na Pomorzu z okresu rzymskiego i ze średniowiecza* (Acta Archaeologica Lodziensia Nr 34) Wrocław-Warszawa-Kraków-Gdańsk-Lódź (1988)
- A Maspero I frammenti di tessuto sui reperti longobardi di Castelli Calepio in P.M. de Marchi & S Cini *I reperti altomedioevali nel civico museo archeologico di Bergamo* Bergamo (1988) 204-219
- T Nakaoka K Aikawa H Miyajima T Yoshii and T Nishizawa The textile history of Nishijin (Kyoto) East meets West *Textile History* 19 no 2 (1988) 117-142
- S M. Newton *The Dress of the Venetians 1495-1525* Scholar Press Aldershot ISBN 0 85967 735 4 Price £28 50 plus postage 208 pp incl 35 monochrome and 9 colour illustrations
- J Rajab *Palestinian Costume*, Kegan Paul London (1989 £35 textiles and embroidery of the *baladin fellahin bedu*)

- K Riboud China s buried past *Hali* 34 (1988) 33-41
- M. E. Rogers *Domestic Life in Palestine* Kegan Paul London (1989) £12 95 Mrs Rogers lived in Palestine during the 1850 s The book contains sections on the customs and dress of Bedouins Samaritans Druses Muslims and Jews)
- H C Ross *The Art of Arabian Costume* Kegan Paul London (1989) £35
- H C Ross *The Art of Bedouin Jewellery* Kegan Paul London (1989) £35
- I Schierer Ein Webstuhlfund aus Gars-Thunau Rekonstruktionsversuch und Funktionsanalyse *Archaeologica Austriaca* 71 (1987) 29-87
- E Schølberg Cordage and similar products from Bryggen in Bergen *The Bryggen Papers* supplementary Series no 3 (1988) 69-138
- C Semple *Traditional Jewellery and Ornament of the Sudan* Kegan Paul London (1989) £35
- A Sheffer Textiles and textile impressions on pottery in B Rothenburg *The Egyptian Mining Temple at Timna* Institute of Archaeology London (1988) 224-232
- J Smit *Internationale Weefdictioneire* Haarlem, (1981 one word references also given in Danish German English French Italian Dutch Norwegian and Swedish)
- F Stamati Tekstile dhe Gjurma Tekstileshe nga Germimet Arkeologjike *Kultura Popullore* 2 (1986) 163-180 (In Albanian the title reads Textiles and traces of textiles from archaeological excavations)
- F Sorber Textiel uit de kathedraalbodem" *Scharnier* Kathedraal van Antwerpen Periodiek informatieblad over de opgravingen en de restauratiewerken no 3 (maart 1988) 5-6
- M. Swain *Tapestries and Textiles at the Palace of Holyroodhouse in the Royal Collection* HMSO London ISBN 0 11 493421 5 Price £18 plus postage 80 pp incl monochrome and colour illls
- G M. Vogelsang-Eastwood *The Akhmim Weave*, Cairo (1988)
- G M. Vogelsang-Eastwood *Zilu carpets from Iran* *Studia Iranica* 17 no 2 (1988) 225-240
- P Walton Caulking cordage and textile in C O'Brien L Brown S Dixon R Nicholson *The Origins of the Newcastle Quayside (Soc Antiq Newcastle upon Tyne Monograph series 3)* (1988) 78-85
- P Walton A tangled web *Interim* 13/3 (1988) 32-38
- J P Wild review of John Becker Pattern and loom a practical study of the development of weaving techniques in China Western Asia and Europe *Antiquity* 62 (1988) 816-818
- I Øye *Textile Equipment and its Environment Bryggen in Bergen c 1150-1500* (The Bryggen Papers Main Series vol 2) Norwegian University Press (1988) Distribution P O Box 2977 Tøyen N-0608 Oslo 6 Norway
- I Estham and M. Nockert (eds) *Opera Textilia Variorum Temporum* (Festschrift for A Geijer The Museum of National Antiquities Stockholm, Studies 8) Stockholm (1988) It contains
- D Strömbäck "Devoted to science" 13-16
- I Estham, Eighty years of Pietas 17-22
- W Endrei "Über Blöckchendamaste" 23-28
- I Bergman The triangular Nubian textiles How were they produced? 29-32
- M. Flury-Lemberg A recent silk find from Antinoë 33-40
- G Arwidsson Birka III - Agnes Geijer s doctoral thesis 41
- U Cyrus-Zetterström, A monochrome patterned silk fabric among the finds from Birka 45-48
- E E Guðjónsson Romanesque gold embroidered vestments from the Cathedral church at Hólar Iceland 49-66
- D and M. King Silk weaves of Lucca in 1376 67-76
- K Stolleis Ein spätgotischer Kaselbesatz aus dem Umkreis des Meisters von Alkmaar 77-92
- I Estham, A newly discovered intarsia and gold leather embroidery 93-110
- M. Nockert Precious coats from the fifteenth century 111-120
- B Gyllensvärd A Chinese embroidery of the seventeenth century used in Sweden as a patchwork quilt 121-131
- M. Hoffmann Of knitted nightshirts and detachable sleeves in Norway in the seventeenth century 131-144

A Kjellberg Knitting and the use of knitted goods in Norway before 1700 From archaeological finds to documentary evidence 145-152

B Schmedding Considering the repeat of woodblock printed textiles 153-166

Å Nisbeth For everyday use 167-170

S Fogelmarck John Böttiger - keeper of textiles 171-180

M. Wang To dress for joy From Sigrid Undset to Vanja Brunzell 181

EXTENDED BIBLIOGRAPHIES

BAO MINGXIN

(Please note that the following unless otherwise stated are written in Chinese)

Preliminary Research of Zhanghua satin *Journal of the East China Institute of Textile Science and Technology* no 3 (1983)

Brocade of double weave in Ancient China *Silk* no 8 (1984)

The silk velvets in Ming and Qing Dynasty *Research on Silk History* 4 (1984)

25 entries in the *Chinese Encyclopaedia (Textile)* Chinese Encyclopaedia Press (1984)

The origin and development of Jiado *Silk* no 6 (1985)

with Gao Hanyu *Patterns Through the Ages* The Commercial Press Ltd Hong Kong (1986)

A review of Chinese historical textiles research *Sea of Book* November (1986)

The monochrome figured silk in Ancient China *Journal of China Textile University* no 1 (1986 English edition)

Early history of satin *Journal of China Textile University* no 1 (1986)

Modern textile journals in China before 1949 *China Textile* no 2 (1987)

Chinoiserie in European textiles and clothing *Journal of China Textile University* no 1 (1987)

Costume in Sui Tang and Five Dynasties *Journal of China Textile University* no 2 (1988 English edition)

300 entries about textiles and clothing in the *Dictionary of Chinese Culture* Shanghai Social Science Institute Press (1988)

ELISABETH MUNKSGAARD

Oltidsdragter Copenhagen (1974)

Frisurer fra ældre jernalder *Aarbøger for nordisk oldkyndighed og historie* 1976 (1978) 5-21

Det såkaldte kohorn fra Øksbjerg omspundet med hør *Aarbøger for nordisk oldkyndighed og historie* 1979 (1980) 5-10

The Gallic coat from Rønbjerg in L Bender Jørgensen and K Tidow (eds) *Textilsymposium Neumünster Archäologische Textilfunde* Neumünster (1982) 41-43

with L Bender Jørgensen and K-H Størnø Nielsen Melhøj-fundet En hidtil upåagt parallel til Skrydstrupfundet *Aarbøger for nordisk oldkyndighed og historie* 1982 (1984) 19-57

The embroideries from Bjerringhøj Mammen *Festskrift til Thorleif Sjøvoll Universitets Oldsaksamlings Skrifter* ny række 5 (1985) 159-171

with E Østergaard Textiles and costume from Lønne Hede An early Roman Iron Age Burial in L Bender Jørgensen B Magnus and E Munksgaard (eds) *Archaeological Textiles Report from the 2nd NESAT Symposium 1-4 V 1984 Arkæologiske Skrifter* 2 Copenhagen (1988) 53-64

LIST OF SUBSCRIBERS

-S H Abels and C Abels-Klarenbeek Dalweg 12 NL 9464 TE Eexterzandvoort The Netherlands
 N K Adams 957 Wolf Run Road Lexington KY 40504 USA
 C Alfaro Gobernador Viejo 34 46003 Valencia Spain
 -J Allgrove McDowell 13 Powis Villas Brighton BN1 3HD England
 H M Appleyard 8 Bridle Stile Shelf Halifax HX3 7NW England
 A Baker 138 Lugarno Parade Lugarno N S W 2210 Australia
 M Ballard CAL/MSC The Smithsonian Institute Washington D C 20560 USA
 Bao Mingxin Department of Clothing China Textile University 1882 West Yan-an Road Shanghai Peoples Republic of China
 E Barber 1126 North Chester Ave Pasadena CA 91104 USA
 J C Barnett Henry Moorepassage 114 2907 MG Capelle aan den IJssel The Netherlands
 L Bender Jørgensen Bryggerivej 8 ** DK 2500 Valby Denmark

- A Bergli Historisk Museum Konservering
savdelingen Årstadsvollen 22 N-5000 Bergen
Norway
- M Bergstrand c/o Emaus Vildgåsvägen 11A S
22235 Lund Sweden
- J and T Beswick Diddies House Stratton
Bude N Cornwall EX23 9NE England
- K M Boe Stationsgade 20 OK 8240 Risskov
Denmark
- H Bohmer Istanbul Bebek Küçük Deresi sok 9
Turkey
- R Boyer Centre de Recherches Archéologiques
Laboratoire de Conservation Restauration et
Recherches 19 rue Frédéric Mireur F 83300
Draguignan France
- J S Brandford 200 Brookfield Rd Ithaca New
York 14850 USA
- M M Brooks 51 Westwood Terrace Bishopthorpe
Road York YO2 1HJ England
- A M Cadoux 27 Gayfield Square Edinburgh EH1
3PA Scotland
- J Cocking Darwin College Cambridge England
- W Cooke Dept of Textiles UMIST PO Box 88
Manchester M60 1QD England
- E Crowfoot River View Big Row Geldeston
Beccles Suffolk NR34 0LY England
- Z C Curel Borı I Fontesta 23 08021
Barcelona Spain
- J Cutter 9 Gloucester Road Teddington
Middlesex TW11 0NS England
- C D DeRoche 32 Warren Lane Martlesham heath
Ipswich Suffolk IP5 7SH England
- J Dosogne Lafontaine Musées Royaux d Art et
d Histoire Parc du Cinquantenaire 10 B 1040
Bruxelles Belgium
- C van Driel Murray Laan van Ouderzorg 107
2352 HL Leiderdorp The Netherlands
- E Dubuc 5960 Saint Urbain Montreal Quebec
Canada H2T 2X5
- M Fentz Norupvej 44 Vammen OK-8800 Viborg
Denmark
- K Finch 7 Western Gardens London W5
England
- E French Ashburne Hall Old Hall Lane
Manchester M14 6HP England
- T Gabra Sanders 18 Craighleith Hill Park
Edinburgh EH4 2NR Scotland
- J Gardiner 752 S 16th St Philadelphia PA
19146 USA
- R Germer Sierichstraße 16 2000 Hamburg 60, W
Germany
- M Gittinger 4100 Cathedral Ave Washington DC
20016 USA
- H Granger Taylor 22 Park Village East
London NW1 7P2 England
- E E Guðjónsson National Museum of Iceland PO
Box 1499 IS 121 Reykjavik Iceland
- R Hall Petrie Museum of Egyptian Archaeology
University College Gower Street London WC1E
6BT England
- L Heckett Dept of Archaeology University
College Cork Ireland
- A Hedeager Madsen Lollandsgade 63 OK 8000
Århus C Denmark
- J M G Helaholt Tuinfluiterslaan 35 NL 2566
SJ Den Haag The Netherlands
- L Hillyer Textile Conservation Victoria and
Albert Museum Cromwell Road London SW7 2RL
England
- M Hoffmann Almevegen 28 Oslo 8 Norway
- P van t Hooft Reek 13 2121 GT Bienenbroek
The Netherlands
- R C Janaway School of Archaeological
Sciences The University of Bradford Bradford
W Yorkshir BD7 1OP England
- L Vig Jensen Kulturvernet for Svalbard og Jan
Mayen Tromsø Museum N 9000 Tromsø Norway
- A Johnson Rønnnekrogen 13 OK 3400 Hillerød
Denmark
- D De Jonohe Koninklijke Musea voor Kunst en
Geschiedenis Jubelpark Brussels Belgium
- N Kajitani The Metropolitan Museum of Art
Fifth Avenue at 82nd Street New York NY 10028
USA
- E L Kalf Westerhoutstraat 32 NL 2012 JS
Haarlem The Netherlands
- N Kerr Dept of Clothing and Textiles Faculty
of Home Economics 301 Printing Services
Building University of Alberta Edmonton
Canada T6G 2N1
- D King 5 Taylor Avenue Kew Richmond Surrey
TW9 4EB England
- G van der Kooij Marienpoelstraat 57 Leiden
The Netherlands
- L W F Lee 100 Post Office Road Waccabuc NY
10597 USA
- P van de Lee Harms Statenjachtstraat 494 NL
1034 EW Amsterdam The Netherlands
- M Lindstrom Skåbevagen 18 222 28 Lund
Sweden
- S Lovengard P O BOX 6611 New York 10128
USA
- D O R Lugtigheid Duvenwoordestraat 86 2013
AH Haarlem The Netherlands
- I Lutzen Enggårdsvvej 8 OK 3060 Espergaerde
Denmark
- W I Mackay 130 Maidmont Road Edinburgh
EH9 1AA Scotland
- L M Mackie Royal Ontario Museum 100 Queen s
Park Toronto Ontario Canada M5S 2C6
- C McClintock Redhall Ballycarry,
Carrickfergus Co Antrim N Ireland
- A Malmius Riddarvagen 27 A 18132 Didingo
Sweden
- A De Moor Windekekeouter 90 9258
Scheldewindeke Belgium
- N Moore 5 Rue Eliane F 92190 Meudon Haut de
Seine France
- A Morrell 119 Berwick Avenue Heaton Mersey
Stockport Cheshire SK4 3AT England
- D Mott c/o J Powell Samanyolu Sok 97 Sisli
Istanbul Turkey
- E Munksgaard Kastanievej 2 OK 2960 Rungsted
Kyst Denmark
- H Moustafa Kamal 83 Talal Saad Allah Street
El Haram Street app 8 Cairo Giza Egypt
- K H Nielsen Hulsøvang 17 OK 2960 Rungsted
Kyst Denmark
- S Niessen Faculty of Home Economics 115 Home
Economics Building The University of Alberta
Edmonton T6G 2M8 Canada
- G Owen Crocker The English Department
University of Manchester Oxford Road
Manchester M13 9PL England
- E Peacock Dept of Textiles UMIST PO BOX 88
Manchester M60 1QD England
- I R Pedersen Konserveringsbygget Årstadveien
22 N 5000 Bergen Norway

-I Petrascheck Heim A 1190 Wien Dionysius
Andrassy Strasse 16 Austria
N Postgate Faculty of Oriental Studies
Sidgwick Avenue Cambridge CB3 9DA England
J Powell Samanyoku Sok 97 Sisli Istanbul
Turkey
K Prangsgaard Spobjergvej 173 OK 8220
Braband Denmark
-F Pritchard Dept of Urban Archaeology Museum
of London London Wall London EC2Y 5HN
England
-K Riboud 54 Avenue de Breteuil 75007 Paris
France
F Roberts Konserveringsanstalten Vester-gade
5 7 OK 6870 Ølgod Denmark
A T van Rosevelt 2025 Norway Road Ann Arbor
Mich 48104 USA
M L Ryder 4 Osprey Close Southampton SO1
8EX England
K Sakamoto 13-25 Tennoji Ku Shinpoin Cho
Osaka 543 Japan
H Sancisi Klassiek Instituut Pleiadenlaan 10
26 NL-9742 NG Groningen The Netherlands
B F Schweger 6 213 Biological Sciences
Building Boreal Institute for Northern Studies
University of Alberta Edmonton Alberta Canada
T6G 2E9
-T Schick The Israel Museum Jerusalem 91012
Israel
E Schølberg Allégt 38 N 5000 Bergen Norway
A Sheffer Institute of Archaeology Tel Aviv
University Ramat Aviv 69 978 Tel Aviv P O B
39040 Israel
-F Sorber 438 TB B 2110 Wihnegem Belgium
G Spicer 17 Cedar Road SD Katonah NY 10536
USA
B Stenberg Tyrefor Alvag 6 19441 Upplands
Vasby Sweden
H M Stevens The Mill House Market Weston
Diss Norfolk, IP22 2PE England
-M Straub 67 Highsett Hills Road
Cambridge CB2 1NZ England

R Striemer Hochsitzweg 83 1000 Berlin 37
West Germany
N Tarrant Royal Scottish Museum Chambers
Street Edinburgh EH1 1JF Scotland
G Tata P O Box 8414 Salt Lake City Utah
84108 USA
G Taylor 46 Harlow Moor Drive Harrogate
North Yorkshire England
C Thorpe 15 Hermitage Road London N4 1DF
England
K Tidow Textilauseum 2350 Neumunster 1
Postfach 2640 + 2660 W Germany
V Tudhope 19 Fowler Terrace Edinburgh EH11
1DB Scotland
-D Tweddle York Archaeological Trust 1
Pavement York YO1 2NA England
M Verhecken Lammens Ed Arsenstraat 47 2510
Mortsel Belgium
F Vlaanderen Hooglandsekerkgracht 12 2312 HT
Leiden The Netherlands
G van der Vloet Grensstraat 5 B 3200 Kessel
lo Belgium
G M Vogelsang Eastwood Van Swietenstraat 45
NL 2334 EA Leiden The Netherlands
S Vons Comis Griend 87 NL 1112 KZ Diemen The
Netherlands
P Walton Garden Flat 12 Bootham Terrace
York YO3 7DH England
D Waterhouse Anivad Textile Arts 26 Mostyn
Gardens London NW10 5QX England
S Wikstrom Bergvik Ådo S 19700 Bro Sweden
J P Wild Dept of Archaeology Manchester
University Manchester England
F Wortman Elzenhoven 15 NL 2245 RC
Kwintshoul The Netherlands
C Wyaux Rue des Meuniers 4 B 5973 Glines
Belgium
M A van Zeist Slager Wilhelminalaan 9 NL
9781 CT Bedum The Netherlands
W H Zimmermann Vor der Burg 26 O 2935
Bockhorn W Germany

